

# PowerLux® eShoeBox

## 23" Elite Luminaire



Shown with Pole Mount

### FIXTURE DIMENSIONS

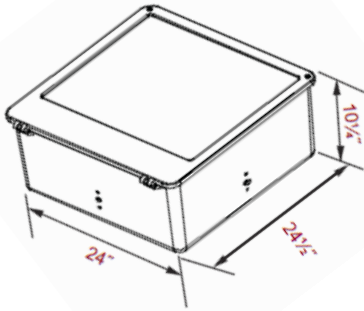

### IES FILE PHOTOMETRIC DATA

Available upon request

### PACKING DATA

Carton size: 28"x28"x14" Weight: 34 lbs

### ORDERING INFORMATION & SELECTION

Model No.	Wattage	Lamp Kelvin	Voltage	Mounting Device
PESB	315W	930	120V *	Pole Mount Square (PM)
		942	277V	Pole Mount Round (PMR)
			480V *	Slip Fitter (SF)
				Trunnion (TR)

\*with transformer

Elite lamps do not re-ignite instantly. Warm re-ignition time is specified to be less than 15 minutes, typically around 10 minutes.

Part Number Example PESB/315/930/277/SDT/TR

Description: PowerLux eShoeBox 23" Elite Luminaire 315W 3000K 200-277V with Step-down 480V:277V transformer and Trunnion Bracket

Catalog#		Type
Project		
Note		Date
Prepared by		

**Uses Proven Philips MasterColor® CDM Elite**

### **APPLICATIONS**

For outdoor lighting: walkways, parks, floodlighting of buildings and parking lots.

### **SPECIFICATION FEATURES**

- Superior, long-lasting white light
- Efficient electronic ballast that uses less energy than magnetic options
- Available in 210W, 1-10V, 50% load dimmable ballast; up to 80,000 hours life
- 93% efficiency for electronic ballast; Ballasts give ignition pulses of 4 kV maximum
- Surge protection (100 kHz ring wave) of 6 kV
- Color Rendering Index CRI 90+
- Compact lamp design in combination with accurate lamp fixation, enabling high optical efficiencies
- Excellent color quality and consistent light output from beginning to end
- Lamp efficacy: 210W, 108 lm/w and 315W, 113 lm/w
- Light output: (3000K) 210W = 24150lm 315W = 38700lm  
(4200K) 210W = 23000lm 315W = 35500lm
- Average lamp life: 30,000 hours (315W) and 27,000 hours (210W)
- Die-cast aluminum housing with powder coated bronze paint finish
- Safety tempered glass lens; Silicon rubber gasket
- Aluminum reflector designed for maximum photometric efficiency and optimum light distribution
- Cut-off distribution complies with Dark Sky compliance
- UL listed for wet location
- Perfect replacement for HPS and MH HID light sources
- Overall weight is reduced for easy installation and maintenance
- Manufactured in the U.S.A.
- Mounting Accessories:  
Pole Mount (Round or Square Pole)  
Slip Fitter (O.D. 2.4" adjusts 180 degrees)  
Trunnion (Adjusts 180 degrees and can be locked)
- Part of Philips Green Flagship product line to minimize environmental impact and CO<sub>2</sub> emissions

## **PowerLux® Corporation**

**U.S. Manufacturer of Sustainable Energy Efficient Lighting Products**

1260 Liberty Way, Suite E Vista, CA 92081 Phone: 760-727-2360 Fax: 760-434-4766

Website: www.powerlux.com E-mail: klpowerlux@gmail.com

**PowerLux® Products Have Stood the Test of Time!**